



SJ35-04

GARDEN WATERING SYSTEMS

Your rainwater tank captures and saves water. To use it effectively around the garden Davey has developed the Silver Series® of pumps to economically satisfy these needs.

Davey are known worldwide for the quality and reliability of their pumps, and the new Silver Series® has been developed to live up to this enviable reputation.

While the domestic backyard may not be as harsh as the Australian outback, Davey know that reliability is just as important to you. Silver Series® pumps are manufactured to the exacting standards Davey have established for all their products. Important components like bearings, capacitors, seals, controls and tanks have all been specified to Davey's standards. The Silver Series® pump will provide a dependable, value for money investment.



SJ35-04P2C/LOP



SJ60-08PC



SJ35-04PC

MODELS

SJ35-04

This is a manual pump, suitable for connection to a standard power outlet and switched on and off as required. No closed head or loss of prime protection is included with this model.

SJ35-04P2C/LOP

This is an automatic model, suitable for connection permanently to a power supply and will start and stop according to pressure demand. The unit comes complete with a 2 litre pressure tank and unique Davey designed LOP pressure switch. This model has partial closed head protection as well as low pressure cut-out to provide loss of prime protection.

SJ35-04PC & SJ60-08PC

These are automatic models, suitable for connection permanently to a power supply and will start according to demand and stop according to flow demands. These models have anti-cycling controls; they are less likely to stop and start under low flow conditions. These models have both closed head protection as well as loss of prime protection.

OPERATING LIMITS

Capacities to	80 lpm
Pressure heads up to	42m
Max. operating pressure	600kPa
Max. incoming (suction) pressure	140kPa
Max. ambient temperature	50°C
Max. water temperature	45°C
Min. water temperature	1°C
Single phase	1 x 230V ± 10% (supplied with 3 pin plug)
Frequency	50Hz
Protection (motor)	IP55

Suitable Fluids

Clean potable water of neutral ph containing no solids or abrasives.

FEATURES & BENEFITS

PUMP

Single stage jet assisted centrifugal pump

- Higher operating pressures
- Less moving parts for increased dependability
- Self priming for easier installation

Corrosion resistant and stainless steel pump components

- Longer life when pumping a variety of water qualities
- Reduced friction within the casing and impellers

High quality purpose built 2 pole, 50Hz, IP55 TEFC pump motors, designed to Davey's high quality specifications with

- Permanent split capacitor starting for dependable and frequent starting everytime
- In-built thermal overload for long motor life and protection against motor damage due to jamming
- High quality sealed bearings for longer life
- Fitted with a power lead and three pin plug for ease of connection to power supply
- Resists ingress of dust & dirt

Hydraulic assembly attached to motor bracket at 8 points with oring seal to the stainless steel pump casing

- Better sealing
- Longer service life

Designed with the serviceman and installer in mind

- Suction and discharge are close for easier installation
- Quality components throughout for long life and easier maintenance

Every pump is performance and pressure tested in the factory to ensure quality and reliability

TANK

Captive diaphragm held firmly in a central position

- Less movement allowing use of a thicker diaphragm material than a bag or bladder tank for longer life

Heavy duty butyl diaphragm meets EEC requirements for potable water applications

- Safe, non-toxic

Safe potable grade epoxy coating seals the water from the tank shell

- Longer life

Deep drawn steel shell with appliance like epoxy enamel finish

- Protected against rusting for long life

Every tank is individually tested

- Guarantee reliable operation

Compliance with the strict requirements of ISO 9000 quality standards

- Consistency of the product

PRESSCONTROL

In-built check valve for easier installation.

In-built spring & diaphragm shock absorber

- No need for pressure tanks on many installations

No adjustments for operation

- Constant non-cycling pump operation

Solid state electronic control circuit with "tropicalization" treatment

- Longer life

Loss of prime protection

- Saves pump from damage when water supplies run out

LOP PRESSURE SWITCH

Reliable mechanical pressure switch for

- Easy servicing
- Outstanding reliability even in poor or "dirty" electrical supply regions

LOP feature will shutdown when the pump pressure drops to 35kPa (5psi) below cut-in (factory settings : cut-in 140kPa/20psi & cut-out 280kPa/40psi)

- Saves pump from damage when water supplies run out

The SJ35-04P2C/LOP is also equipped with a special flow restrictor in the discharge to ensure the system will not engage the "Loss of Prime" protection feature unnecessarily. This flow restrictor is inserted between the discharge tee assembly and the outlet nipple.

ELECTRICAL DATA

Model number	SJ35-04	SJ60-08
Nominal rpm	2900	
Volts / hertz / phase	220-240 / 50 / 1	
IP rating	55	
Amps (run)	2.35	4.8
kW (P ₁) / (P ₂)	0.53 / 0.37	1.16 / 0.9
Capacitor	13 μ F	20 μ F
Insulation class	F	

MATERIALS OF CONSTRUCTION

PART	MATERIAL
PUMP	
Impellers	304 stainless steel
Pump casing	304 stainless steel
Pump shaft	304 stainless steel
Seal ring (stationary): SJ35-04	Ceramic
Seal ring (stationary): SJ60-08	Silicon Carbide
Seal ring (rotating)	Carbon
Seal ring elastomer	EPDM
Seal spring: SJ35-04	304 stainless steel
Seal spring: SJ60-08	316 stainless steel
O-ring	EPDM
Jet/venturi/cover plate	Glass filled thermoplastic
Motor shell	Aluminium
Motor shell finish	Polyester
TANK	
Tank shell	Steel
Tank finish	Epoxy powdercoat
Diaphragm	Butyl rubber
Tank inner coating	Potable grade epoxy powdercoat
Tank inlet	Steel with special inner lining
PRESS CONTROL	
Housing	Glass fibre reinforced polyamide PA 6 GF 30%
Diaphragm	EPDM
Spring	Steel C 72 UNI 3545
Flow valve	Brass OT 58 UNI5705/65
Check valve	Glass fibre reinforced polyamide PA 6 GF 30%
Control box	Self extinguishing thermoplastic resin VO
Printed circuit	Vetronite

DIMENSIONS

Note: SJ35-04P2C/LOP is supplied with a externally mounted inlet check valve which is 120mm long when installed.

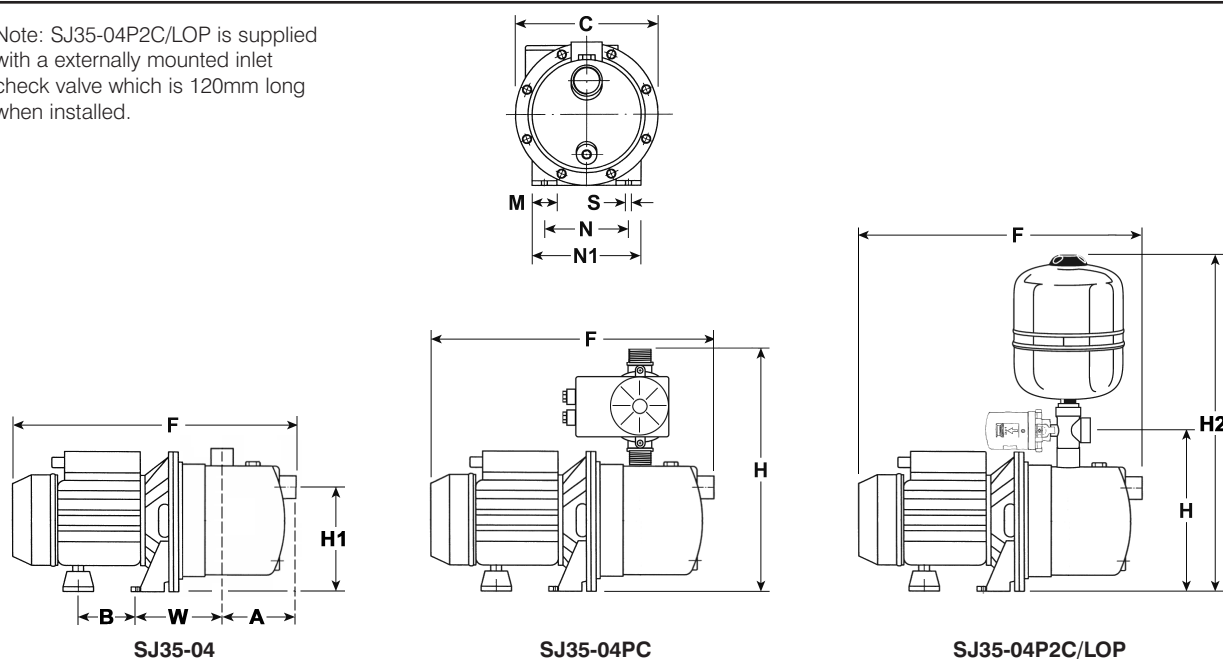

Model	A	B	C	F	H	H1	H2	M	N	N1	S	W	Inlet BSP	Outlet BSP	Net Weight kg
SJ35-04	90	82	170	355	174	128	N/A	30	100	130	7	107	1" F	1" F	5.6
SJ35-04P2C/LOP	90	82	170	355	205	128	483	30	100	130	7	107	1" F	1" M	7.4
SJ35-04PC	90	82	170	355	323	128	N/A	30	100	130	7	107	1" F	1" M	7.0
SJ60-08PC	100.5	82	213	415	472	158	N/A	39	120	158	7	142	1 1/4" F	1" M	11.9

All dimensions in mm unless otherwise stated.



Davey Water Products Pty Ltd

Member of the GUD Group
ABN 18 066 327 517

AUSTRALIA Head Office

6 Lakeview Drive,
Scoresby, Australia 3179
Ph: +61 3 9730 9222
Fax: +61 3 9753 4100
Website: www.davey.com.au

Customer Service Centre

Ph: 1300 369 100
Fax: 1300 369 119
E-mail: sales@davey.com.au

NEW ZEALAND

7 Rockridge Avenue,
Penrose, Auckland 1061
Ph: +64 9 570 9135
Fax: +64 9 527 7654
Website: www.daveynz.co.nz
E-mail: sales@daveynz.co.nz

Customer Service Centre

Ph: 0800 654 333

REST OF WORLD

6 Lakeview Drive,
Scoresby, Australia 3179
Ph: +61 3 9730 9121
Fax: +61 3 9753 4248
E-mail: export@davey.com.au
Website: www.davey.com.au

DEPEND ON
DAVEY

WATER PRODUCTS



This literature is not a complete guide to product usage. Further information is available from your Davey dealer, Davey Customer Service Centre and from the relevant product Installation and Operating Instructions. This data sheet must be read in conjunction with the relevant product Installation and Operating Instructions and all applicable statutory requirements. Product specifications may change without notice.

© Davey is a registered trademark of Davey Products Pty Ltd.
© Silver Series is a trademark of Davey Products Pty Ltd.
© Davey Products Pty Ltd 2010.

HYDRAULIC PERFORMANCE

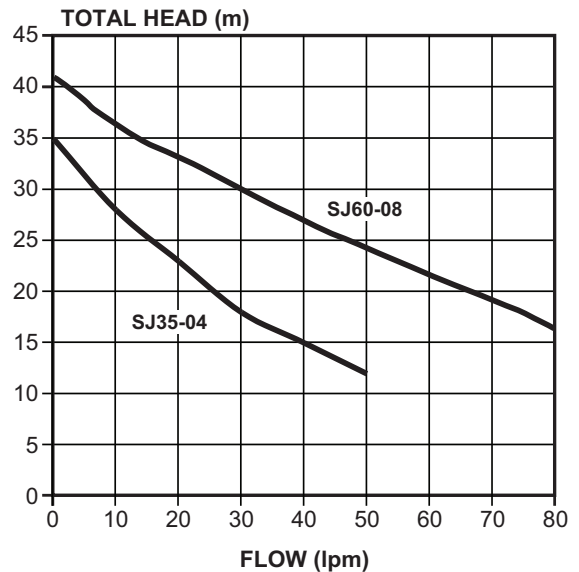

GARDEN WATERING FLOW RATE GUIDE

The SJ35-04 pump models can supply a variety of garden watering applications, such as :-

- A garden hose with a spray nozzle fitted
Or
- A garden spray system with up to 25 microjet sprays
Or
- A garden dripper system with up to 200 garden drippers (4 litre per hour drippers)
Or
- Two small impact sprinklers

The larger SJ60-08PC model is capable of up to double the above, though still suitable for running a single garden hose.

With the correct selection of pipework, valves and automatic irrigation controller, the Silver Series® models can even be used to power a fully automated watering system.

Your garden watering professional can give you the best advice on how to utilise the valuable rainwater you have captured for the most efficient usage in your garden.



Visit Davey on-line for further information
davey.com.au

